



VZN-421H-T5



VZN-441H-T5

## VZN T5 Series

**VIZION** offers systems that assure the highest quality ingredient water at the lowest cost of ownership for premium water filtration. The VZN series couples that assurance with a lower total cost of ownership and smaller footprint.

The VZN systems use self-cleaning ultra filtration ahead of a low-cost carbon cartridge to separate mechanical filtration from taste and odor reduction. This self-cleaning and separation assures the full stated life expectancy of the carbon cartridge and provides it with mechanically pure water, which eliminates premature clogging. These technologies are then followed by template-assisted crystallization to protect your equipment against lime scale buildup.

The VZN systems provide a lower total cost of ownership, ensuring you have an immediate measurable return on your investment compared with your existing system.

### FEATURES AND BENEFITS:

- Separation of mechanical filtration from taste and odor reduction assures long time between cartridge changes.
- Assures only one low-cost carbon cartridge change per year.
- Self-cleaning particle reduction assures low maintenance costs.
- .015 micron ultra filter removes particles 33 times finer than the next best system, assuring consistent high quality water.
- TAC cartridge reduces lime scale by 96–98% without using chemicals or wasting water.
- Maintains good water minerals that provide benefits to customers' health while also creating high-quality drinks.
- Small footprint ideal for foodservice market.
- Several configurations available.

## VZN T5 Series

### Dimensions

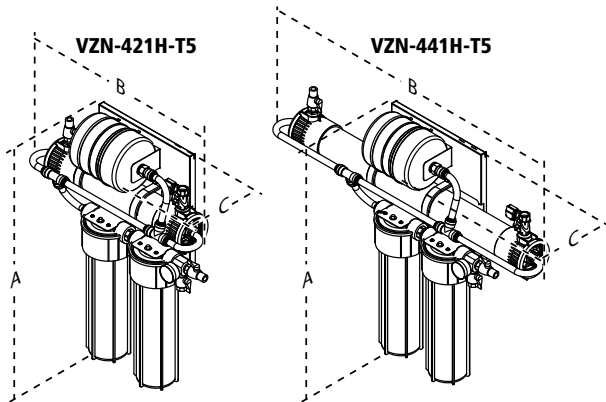

Model & Mfg. No.	Height (A)	Width (B)	Depth (C)	Operating Weight
VZN-421H-T5 9700730	39" (99 cm)	31" (79 cm)	9" (23 cm)	82 lbs. (37 kg)
VZN-441H-T5 9700750	39" (99 cm)	50" (127 cm)	9" (23 cm)	98 lbs. (44 kg)

### Plumbing Connections

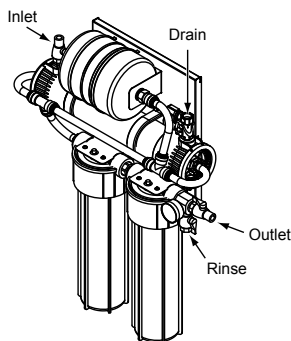

Inlet	3/4" MNPT
Outlet	3/4" MNPT
Drain	3/4" FNPT
Rinse	3/4" GHT

### Electrical Ratings and Plug Configurations

Model & Mfg. No.	Volts	Watts	Amps	Hertz
VZN-421H-T5 9700730	100-240	10	.08	50/60
VZN-441H-T5 9700750	100-240	10	.08	50/60

**NOTE: Includes plug adaptors for US, Europe, Australia, and UK.**

### Capacities

Model & Mfg. No.	Capacity Per Minute	Carbon Lifespan	UF Length	No. of Carbon Elements	No. of TAC Cartridges
VZN-421H-T5 9700730	6.6 gal. (25 liters)	1 year	20" (51 cm)	1	1
VZN-441H-T5 9700750	13 gal. (49 liters)	1 year	40" (102 cm)	1	1

### Specifications (Ultra Filter)

Maximum Operating Pressure	100 psig (690 kPa)
Maximum Operating Temperature	104°F (40°C)
Nominal Pore Size	.015 microns
pH Range	3-10
MWCO	100-150 kD



A.J. Antunes & Co.  
Headquarters/Manufacturing  
180 Kehoe Boulevard  
Carol Stream, Illinois 60188 USA  
Phone (630) 784-1000  
Toll Free (800) 253-2991  
Fax: (630) 784-1650

Antunes Equipment  
Manufacturing (Suzhou) Ltd.,  
9 Hou Ju Road, Building #24,  
S&T Park, SND  
Suzhou, Jiangsu, China 215011  
Phone: 86-512-6841-3637  
Fax: 86-512-6841-3907

[www.ajantunes.com](http://www.ajantunes.com)