

**PC**  
SERIES

FLATWORK IRONERS  
**QUALITY-ORIENTED EFFICIENCY**

PC80  
PC120



**GIRBAU**

# PC SERIES FLATWORK IRONERS

## QUALITY-ORIENTED EFFICIENCY

PC80 / 3000  
3300  
3500



PC120 / 3000  
3300  
3500



## EFFICIENCY AND ROBUSTNESS DESIGNED FOR THE PERFECT FINISH



### PRODUCTIVITY

All parameters are adjusted to achieve better results with any kind of item; with speeds up to 50 m/min on the PC120 and up to 45 m/min on the PC80.



### QUALITY:

All the elements that go to make up the flatwork ironers in the PC series are designed with quality in mind, including the geometry and perfect polished finish of the bed. The combination of an impeccable finish and the latest advances in electronics results in superior ironing quality.



### EFFICIENCY:

The high productivity provided by the separate motors for each of the rolls, the high heat transfer coefficient of the bed and the controllable ironing pressure translate into efficiency for your business. In the gas version, a high efficient burner is available.



### ROBUSTNESS:

The extremely solid, smart construction of the PC series makes them highly resistant to mechanical stresses and thermal expansion. Everything in the PC series is designed to last. That's the aim of the RIGID TECHNOLOGY, one of the most important features of our construction.



### MAINTENANCE:

The machine's optimum design cuts wear on consumables, such as the padding and reduces maintenance work. Moreover, the PC Series are highly accessible, making maintenance tasks easier and shortening work time.

## SENSORY QUALITY: SEE IT, FEEL IT

The results of the PC Series go beyond your business balance sheet.

Your customers can appreciate it right from the start, when they see the impeccable finish of a tablecloth or sheet, when they experience the touch on their fingers of a textile with a crisp feel thanks to the quality of the finish. Quality and efficiency of ironing are more than just productivity and profitability.

The PC series adds value to the image of your establishment through the textiles it produces, showing perfection in detail and caring for materials to prolong the life of your establishment's textiles.



## EXPERIENCE BASED ON OBSERVATION

Is there anything more perfect than nature? Biomimetics, a discipline that exploits the intelligence of nature to apply it to the design of objects, is a clear answer to this question. In laundry, all the processes represent contrasts.

Going from dirty to clean in the washing area, for example, or from crumpled to the perfect smoothness of ironed fabric. The impression caused by ironing is not unlike looking at a sand dune in the desert with a clean line at the top separating a wavy side from a perfectly smooth side.

The PC Series flatwork ironers express smart, tidy, efficient contrast. PC Series, born out of improvement based on observation.

# GIRBAU



### COMFORTABLE TEMPERATURES

The thermal insulation\* in the covers over the flatwork ironers enable you to save energy, take advantage of heat and achieve higher performance.

At the same time, not radiating heat towards the outside makes the environment in the laundry more pleasant, making operators' job easier and enhancing their comfort.

\*optional

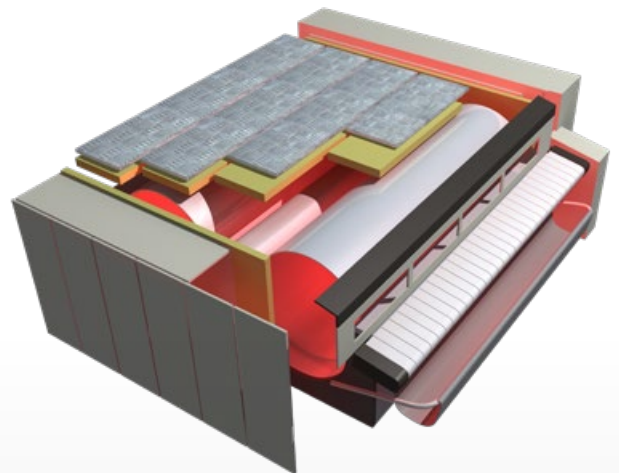

### LONGER LIFE, BETTER RETURNS

The PC Series are machines with a long life cycle to ensure uninterrupted working and a return on the cost of the flatwork ironer.

Proof of our conviction - based on experience - of their long life is that we offer a 12-year guarantee on the bed and bridge.

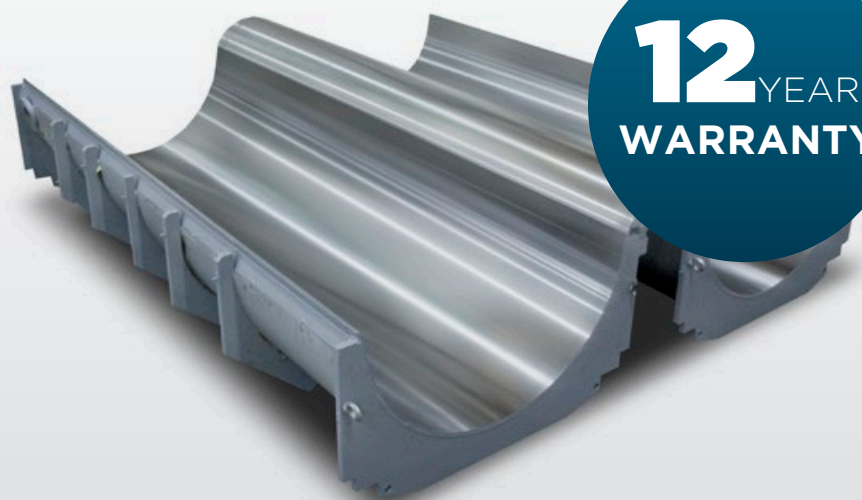

**12** YEAR  
WARRANTY

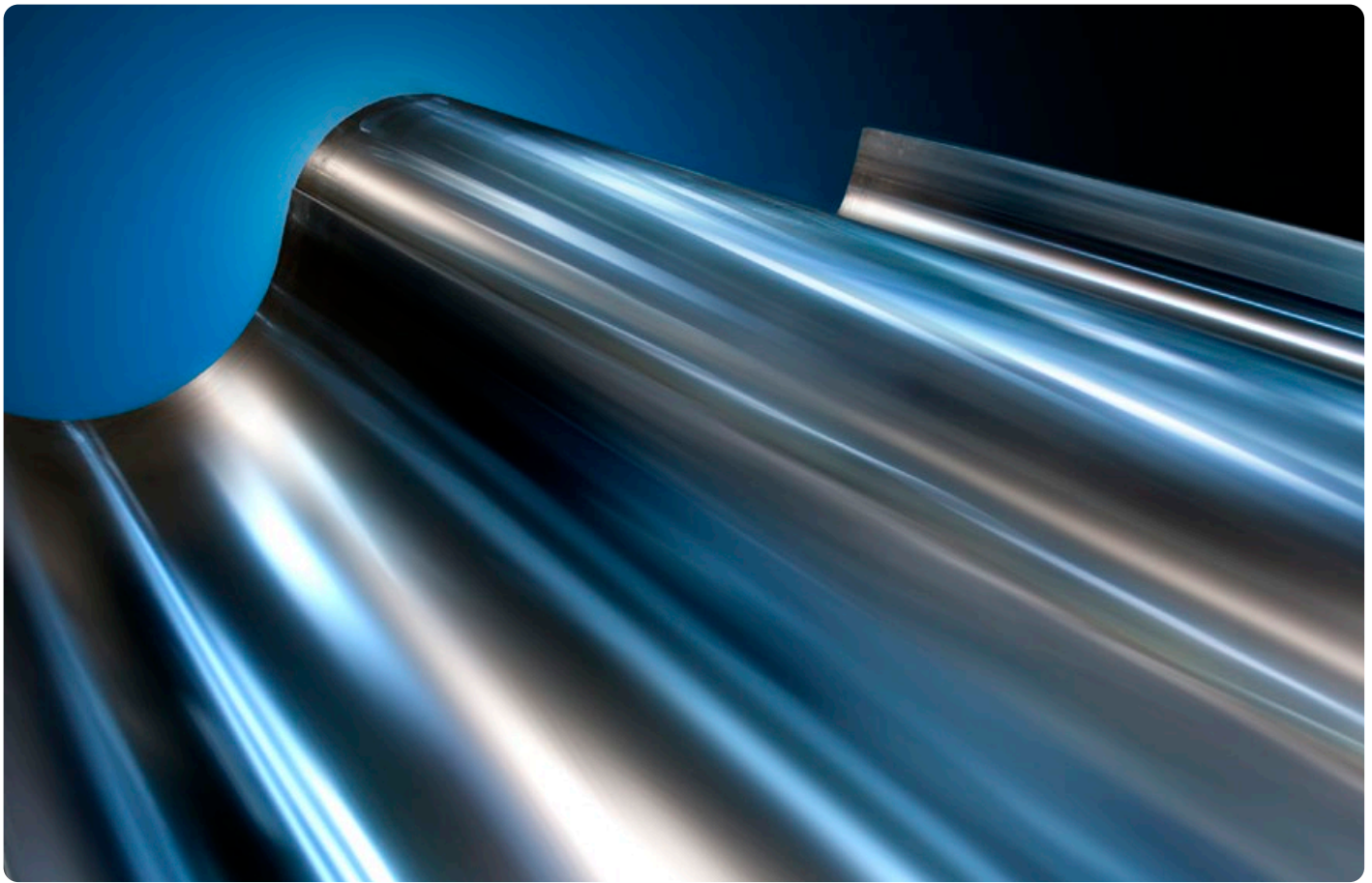

## THE GIRBAU RIGID TECHNOLOGY SYSTEM IS BASED ON FOUR KEY FEATURES

### 1 ROBUSTNESS AND LARGER IRONING SURFACE

**Rigid bed** known for its robustness and finish: the use of three-dimensional design and parametric simulation technology allows Girbau to offer a bed with a wide fluid passage and a capacity for transmitting heat to fabric that make it possible to iron at high speeds while assuring top quality.

Beds are machined after welding, undergo trials at a test pressure of 20 bar and have a final “mirror effect” **finish applied** to ensure excellent results for ironing.

**Larger ironing surface.** The flatwork ironers have a larger ironing surface. Even the bridge between the beds is heated to take maximum advantage of the whole surface area, achieving a better quality and a uniform temperature without causing damaging tensions to the linen.

**Instant temperature** control of the bed in contact with the linen.

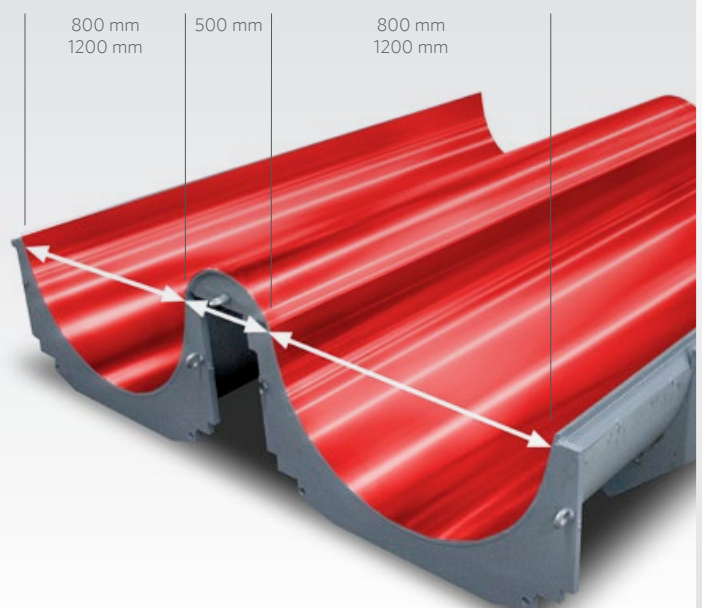



# GIRBAU

2

## UNIFORM TEMPERATURE

The S-COIL design (with a circuit in coil form) assures uniform heating of the whole ironing surface and a total absence of cold areas.

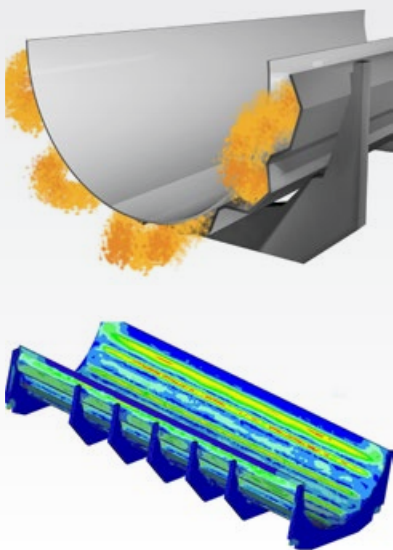

Thermographic image

3

## CONSTANT PRESSURE

A pressure gradient with maximum concentration of diametrical pressure ensures high-quality ironing. Lengthwise pressure along the roll is constant in order to keep ironing uniform.

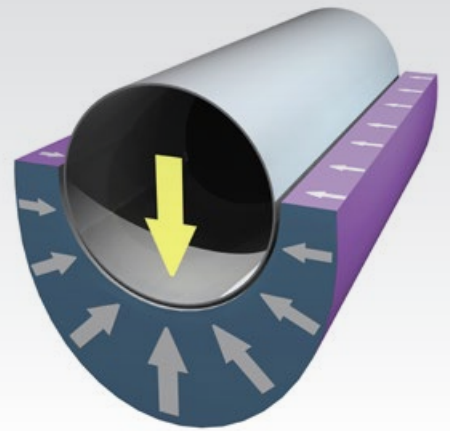

4

## SELF-ALIGNMENT

The floating, self-aligning system enables the flatwork ironer to cope with the thermal expansion and mechanical stresses involved, while maintaining a constant pressure distribution over time.

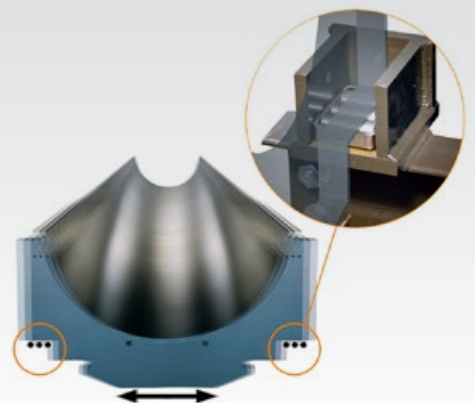



## HIGH PRODUCTIVITY

PC Series flatwork ironers are designed for high production.

The maximum speed for PC 80 is 45 m/min.

PC 120 have a standard speed of 50 m/min.

## EXCELLENT QUALITY CONTROL

Pressure is one of the essential parameters in ensuring a quality finish for good ironing.

This variable can be controlled on PC Series flatwork ironers. The pressure can be set according to the type of textile and ironing requirements\*. With this control, speeds of up to 45 m/min are achieved and thereby increasing productivity.

The bed alignment system ensures uniform lengthwise pressure at a point of maximum pressure, giving maximum quality for the type of textile being processed and it is what sets us apart from others.

\* Optional in PC80 1 and 2 rollers

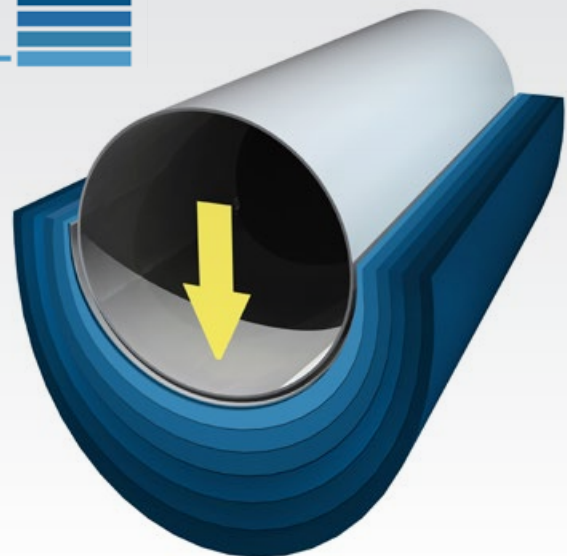

- LOW PRESSURE	HIGH PRESSURE +
<ul style="list-style-type: none"> <li>• Longer padding life</li> <li>• Reduced mechanical fatigue</li> <li>• Lower power consumption by motors</li> <li>• Longer life for textiles</li> </ul>	<ul style="list-style-type: none"> <li>• Higher capacity</li> <li>• Increased drying capacity</li> </ul>



## PROXIMITY AND SPEED

Being fast, efficient and agile is essential to your business.

Proximity to the customer is vital to Girbau, as we realise that this is a key value for any laundry.

As well as being backed by a sales and technical network in more than 90 countries around the world, ready to act quickly and effectively, all PC series flatwork ironers can feature a remote connection,\*

So gaining time and efficiency. Diagnostics can be conducted remotely, with no need to travel.

Information can be captured to analyse productivity, incidents and hours of operation.

**The goal: to gain time and productivity. And above all, to gain peace of mind for you and for your business.**

\* As standard in all models.



Assisting its customers has been and remains one of Girbau's central principles. A wide range to meet the needs of every customer, geographical expansion for closeness, technologies to speed up processes and contact and more.

The success of your business is our goal, our success.

**GROWING TOGETHER**



## EASY MAINTENANCE

### DIRECT TRANSMISSION

The gear motors transmit power to each roll independently and are electronically controlled through latest-generation encoders and inverters that allow the roll speed and the relative speed between them to be adjusted.

Connected via a communications network, they are synchronised with one another in a perfect mechanical transmission system. The transmission requires no mechanical components, so it takes up less space and is easy to maintain.

### ACCESSIBILITY AND SAFETY:

Everything in the PC Series is designed to meet all standards for safety and ease of access. The flat top structure makes it highly accessible to enable the maintenance works. Cleaning the filter is extremely easy. The new look of the casing hides a more ergonomic, accessible, lighter and is easier to take out for maintenance work.

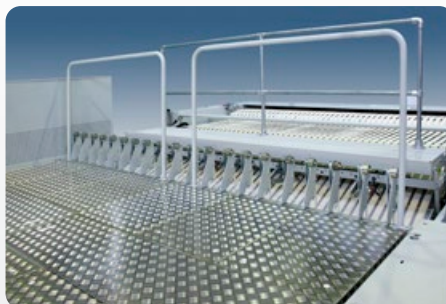

### PLUG & PLAY, EASY INSTALLATION

The structure of PC Series flatwork ironers is designed to make both delivery and installation easy.

Start-up is agile, fast and simple, thereby optimising the installation time.

**There's no time to lose in your business!**







## VERSATILITY IN HEATING SYSTEMS, ALL WITH MAXIMUM EFFICIENCY

### GAS

The 93% efficiency of the gas boiler in the PC Series is achieved thanks to the following:

- A **spacious combustion chamber**: the flame never touches the pipes, to avoid cracking.
- **Multipiping**: the oil circulates through four distinct sets of piping, achieving a higher heating surface area and therefore improved efficiency.
- **Three steam passages**: steam circulates in three ways (flame, between pipes, return). This takes advantage of the temperature of the steam which, through exchange, gives better heating efficiency.



### STEAM AND THERMAL OIL

PC Series flatwork ironers are also available in steam and thermal oil heated versions.

The steam version features temperature\* control, so that it can be set depending on the type of cloth to be ironed.

\*Option



## TECHNOLOGY FOR IMPROVED CONTROL

Setting the ironing parameters easily to meet your requirements is the best way to achieve the desired results and be more efficient.

The PC80 flatwork ironer features PLC technology so that you have maximum control over the process. You can have a programme for each customer or each need. Capacity for 100 programmes allows maximum personalisation of your ironing.

The Girbau flatwork ironing system connectivity software helps you to control all the features of the system for improved control.

### INTELI CONCEPT

Working with the controls of any of the flatwork ironers in the PC Series is extremely easy. The controls feature the Inteli Concept language created by Girbau.

A highly intuitive system of icons means any operator can understand quickly how the machine works.



- + EASY PROGRAMM SETTING
- + EASY TO UNDERSTAND
- MISTAKES



# OPTIONS

	PC80	PC120
<b>Ironing pressure control</b> Allows ironing pressure to be set and adjusted, and increasing the speed.	STANDARD	STANDARD
<b>Modem (connection with factory)</b> Allows remote connection from the factory.	STANDARD	STANDARD
<b>Extra insulation (sides and bed-frame)</b> Additional insulation on all sides of the machine. Enhances the efficiency of the machine and the comfort of the operators as it keeps the heat inside it.	EXTRA	EXTRA
<b>Stainless steel article support tray and manual machine stop pedal</b> (1 roll) To feed in high-quality table linen slowly.	EXTRA	EXTRA
<b>Pressure switch and vapour exit monitoring temperature probe</b> For an exhaustive analysis of steam extraction and more precise diagnosis.	EXTRA	EXTRA
<b>Temperature control (STEAM ironer)</b> Steam pressure regulating valve making it possible to control the temperature of the bed.	EXTRA	EXTRA
<b>Extra for scrapers</b> (1 roll) Used with high-quality table linen.	EXTRA	EXTRA
<b>Pneumatic anti roll drop protection</b> Check valve to keep the rolls up (not for carrying out maintenance).	EXTRA	EXTRA
<b>Output table</b> (only where no folder is installed).	EXTRA	EXTRA
<b>NOMEX padding or equivalent</b> (only for Steam heating) (Gas and thermal oil heating as standard). Standard padding for steam ironers in POLYESTER.	EXTRA	EXTRA
<b>Wood cage packaging</b> Standard packaging is wooden pallet + plastic film.	EXTRA	EXTRA
<b>Special voltage</b> (other than 380-400V/50Hz).	EXTRA	EXTRA

All these options are of factory origin.

## SAFETY

All Girbau equipment fulfill the highest safety standards

2006/42/EC Machine Directive

2006/95/EC Low voltage Directive

2004/104/EC Electromagnetic Compatibility Directive

97/23/EC Pressure Equipment Directive

2009/142/EC Gas Appliance Directive

# IRONING SYSTEM

To achieve high output of high-quality ironing, two basic requirements must be met: having the equipment necessary to set up the right ironing system to meet your needs, and ensuring maximum synchronisation between them.

This is why Girbau offers you a range of options, not only in flatwork ironers but also in feeders and folders to complete the flatwork ironing system.

Our extensive range of equipment means we can be sure that we have the ironing solution best suited to your business.



## DR SERIES FEEDERS

### THE IDEAL SOLUTION FOR IRONING



#### DRE

The DRE is Girbau's most versatile, productive and high-speed feeder ever. It's flexible enough to feed a wide variety of item types into a corresponding ironer, while delivering superior quality results in less time.



#### DRC

This high-speed DRC feeder developed for fast feeding of single bed sheets with cornerless technology.



#### DRBS

DRBS is an automatic feeder which has maximum performances. You can feed up to 900 pieces per hour. Also manual feeding available up to 4 lanes.



#### DR1+

DR1+ Allows one person to feed in up to 300 pieces of linen per hour, on a single lane, and with two people, up to 450 articles can be processed per hour.



#### DRM+

DRM+ is a manual feeder. You can increase the feeding quality, it improves productivity and makes the worker's labour easier.

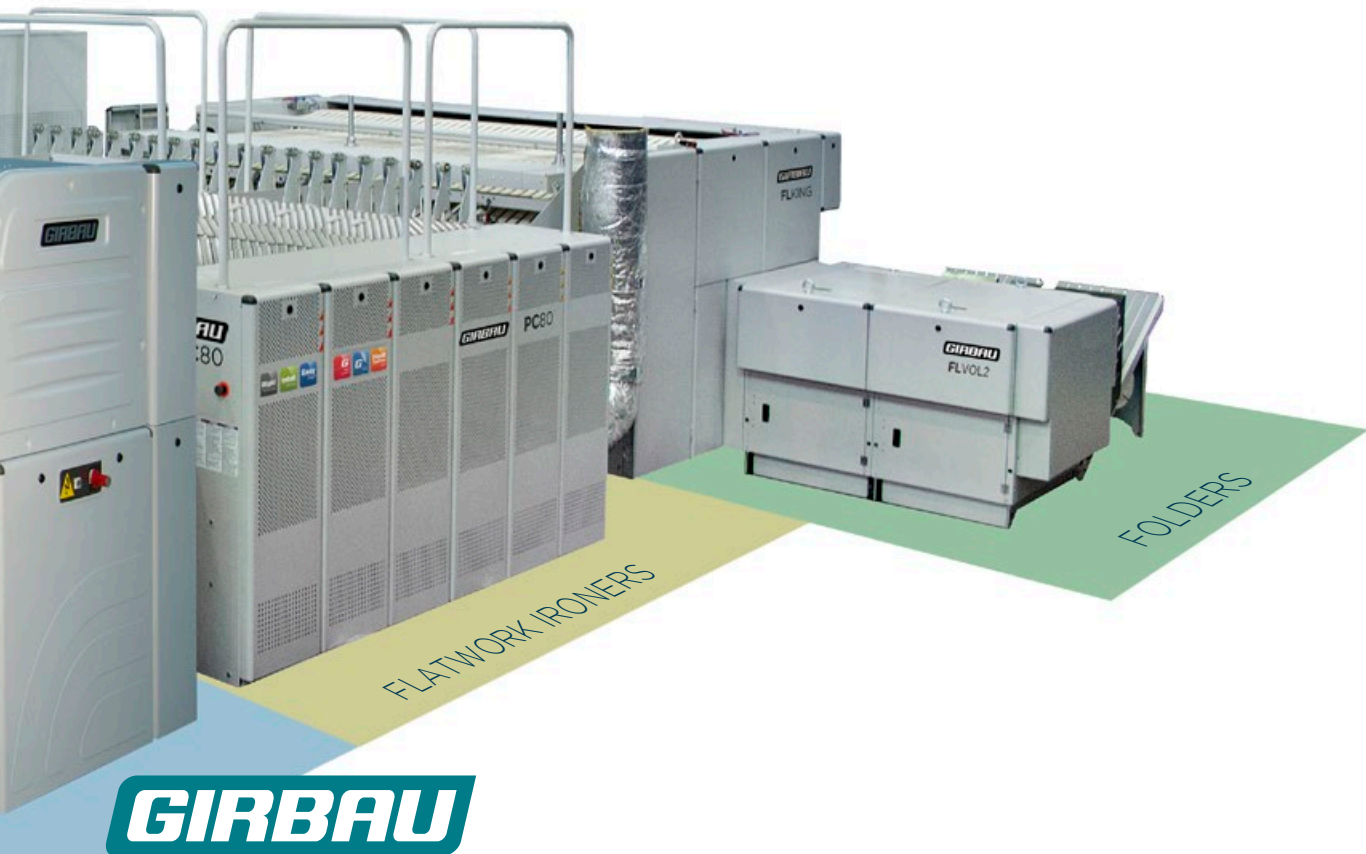

## FR SERIES FOLDERS



### FR+

Flatwork folder up to King Size Standard quality Automatic lanes (Primary folds) on 1, 2 or 4 lanes 2 or 3 primary folds on 1, 2 or 4 lanes 3 cross folds on 1 lane or 2 cross folds on 2 lanes. Available in 3000 / 3300 / 3500 mm.



### FRB

Flatwork folder offers 2 or 3 primary folds in 1, 2 or 4 lanes. Side folding in 1 lane can be combined with 3 cross folds to adapt to the type of item. Robust, simple and open design, making it a fast machine (up to 50m per minute) that is easy to maintain.

# PC SERIES FLATWORK IRONERS

## PC80

MODEL		PC 8030/1	PC 8033/1	PC 8035/1	PC 8030/2	PC 8033/2	PC 8035/2	PC 8030/3	PC 8033/3	PC 8035/3
Cylinder Nr		1			2			3		
Heating surface	m <sup>2</sup> (sq.ft)	3,71 (39.9)	4,08 (43.9)	4,33 (46.6)	9,28 (100)	10,21 (110)	10,83 (116.6)	14,85 (159.8)	16,34 (176)	17,33 (186.5)
Ø Cylinder	mm (in.)	800 (31.5)								
Cylinder length	mm (in.)	3000 (118.1)	3300 (129.9)	3500 (137.8)	3000 (118.1)	3300 (129.9)	3500 (137.8)	3000 (118.1)	3300 (129.9)	3500 (137.8)
Speed	m/min (ft/min)	5 - 45 (16 -147)								
Air flow V - AT - G	m <sup>3</sup> /h (c.f.m.)	1080 (635)			2160 (1271)			3240 (1907)		
Fumes flow - G	m <sup>3</sup> /h (c.f.m.)	455 (268)			663 (390)			-		
Heating power AT	kW (B.T.U./h)	155 (528.5)	170 (579.7)	180 (613.8)	225 (767.25)	250 (852.5)	265 (903.6)	385 (1312.8)	425 (1449.2)	450 (1534.5)
Heating power G	kW (B.T.U./h)	170 (580.0)			250 (853.0)			-		
Steam flow	kg/h (lbs/h)	285 (629)	310 (684)	330 (728)	410 (904)	455 (1004)	485 (1070)	705 (1555)	775 (1709)	820 (1809)
Hot oil flow	l/min (Usgal/min)	520 (138)	575 (152)	605 (160)	760 (201)	845 (224)	895 (237)	1300 (344)	1435 (371)	1515 (401)
Motors power V - AT (50 Hz)	kW	1,1/1,1 5,5			1,1/ 2x1,1 2x5,5			1,1/ 3x1,1 3x5,5		
Motors power G (50 Hz)	kW	1,1/1,1 5,5/4/0,55			1,1/2x1,1 5,5/4/0,55			-		
Ø Steam exhaust V - AT - G	mm (in.)	250 (9.8)								
Ø Fumes exhaust G	mm (in.)	200 (7.9)							-	
Ø Steam Ø Return	in. (mm)	2" (50,8) 1 1/2" (38,1)								
Ø Hot oil Ø Return	in. (mm)	3" (76,2) 3" (76,2)								
Ø Compressed air	in. (mm)	1/2" (12,7)								
Net Weight V-AT	kg (lbs.)	3415 (7529)	3670 (8091)	3840 (8466)	6785 (14957)	7300 (16094)	7645 (16865)	10285 (22675)	11060 (24384)	11580 (25530)
Net Weight G	kg (lbs)	4675 (10307)	4930 (10868)	5100 (11243)	8055 (17759)	8570 (18894)	8915 (19655)	-		
Height V-AT <b>H</b>	mm (in.)	1530 (60.2)								
Height G <b>H</b>	mm (in.)	2363 (93)								
Width <b>L</b>	mm (in.)	4400 (173.1)	4700 (184.9)	4900 (192.8)	4400 (173.1)	4700 (184.9)	4900 (192.8)	4400 (173.1)	4700 (184.8)	4900 (192.8)
Depth V - AT <b>P</b>	mm (in.)	2360 (92.8)			3675 (144.6)			4990 (196.3)		
Depth G <b>P</b>	mm (in.)	2628 (103.4)			3943 (155.1)			-		

V - Steam version  
AT - Hot oil version  
G - Gas version

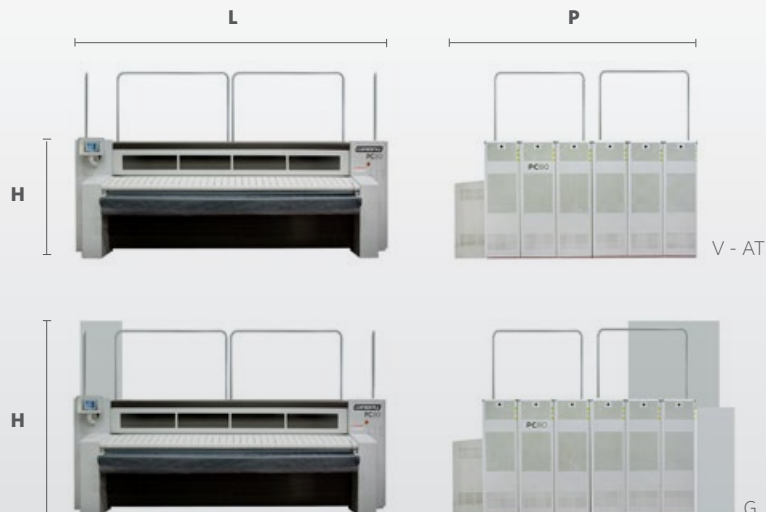

# PC120



MODEL		PC 12030/1	PC 12033/1	PC 12035/1	PC 12030/2	PC 12033/2	PC 12035/2	PC 12030/3	PC 12033/3	PC 12035/3
Cylinder Nr.		1			2			3		
Heating surface	m <sup>2</sup> (sq.ft.)	5,56 (118.1)	6,12 (65.9)	6,49 (69.9)	13 (139.9)	14,28 (153.7)	15,16 (163.2)	20,41 (219.7)	22,44 (241.5)	23,82 (256.4)
Ø Cylinder	mm (in.)	1200 (47.2)								
Cylinder length	mm (in.)	3000 (118.1)	3300 (129.9)	3500 (137.8)	3000 (118.1)	3300 (129.9)	3500 (137.8)	3000 (118.1)	3300 (129.9)	3500 (137.8)
Speed	m/min (ft/min)	5 - 50 (16-164)								
Air flow V - AT - G	m <sup>2</sup> /h (c.f.m)	1650 (971)			3300 (1,942)			5000 (2,943)		
Fumes flow - G	m <sup>2</sup> /h (c.f.m)	663 (390)			1325 (780)					
Heating power AT	kW (BTU/h)	232 (791.6)	255 (870)	270 (921.2)	405 (1381.9)	445 (1518.4)	470 (1603.7)	545 (1859.6)	600 (2047.2)	636 (2170.1)
Heating power G	kW (BTU/h)	250 (853.0)			500 (1706.0)					
Steam flow	kg/h (lbs/h)	423 (933)	465 (1025)	493 (1087)	735 (1620)	812 (1790)	850 (1874)	995 (2194)	1096 (2416)	1162 (2562)
Hot oil flow	l/min (Usgal/min)	782 (207)	860 (227)	910 (240)	1365 (361)	1500 (396)	1585 (419)	1840 (486)	2025 (535)	2145 (567)
Motors power V - AT (50 Hz)	kW	0,9 / 1,1 / 11			0,9 / 2x1,1 / 2x11			0,9 / 3x1,1 / 3x11		
Motors power G (50 Hz)	kW	0,9 / 1,1 / 11 / 4,6			0,9 / 2x1,1 / 2x11 / 11,6			0,9 / 3x1,1 / 3x11 / 11,6		
Ø Steam exhaust V - AT - G	mm (in.)	250 (9.8) t								
Ø Fumes exhaust G	mm (in.)	200 (7.9)			250 (9.8)					
Ø Steam Ø Return	in. (mm)	1 1/2" (38,1) 1 1/2" (38,1)			2" (50,8) 1 1/2" (38,1)					
Ø Hot oil Ø Return	in. (mm)	3" (76,2) 3" (76,2)								
Ø Compressed Air	in. (mm)	1/2" (12,7)								
Net weight V - AT	kg (lbs.)	5145 (11343)	5750 (12677)	6100 (13448)	10215 (22520)	11370 (25067)	12085 (26643)	15285 (33698)	16990 (37457)	18070 (39838)
Net weight G	kg (lbs.)	6470 (14264)	7030 (15498)	7400 (16314)	12358 (27245)	13465 (29685)	14198 (31301)	16921 (3730)	18599 (41)	19710 (43,45)
Height V - AT <b>H</b>	mm (in.)	1850 (72.8)								
Height G <b>H</b>	mm (in.)	2685 (105.7)								
Width <b>L</b>	mm (in.)	4353 (171.4)	4653 (183.2)	4853 (191.1)	4353 (171.4)	4653 (183.2)	4853 (191.1)	4353 (171.4)	4653 (183.2)	4853 (191.1)
Depth V - AT <b>P</b>	mm (in.)	2757 (108.5)			4475 (176.2)			6193 (243,8)		
Depth G <b>P</b>	mm (in.)	3008 (118.4)			4846 (190.8)			6564 (258,4)		

V - Steam version  
AT - Hot oil version  
G - Gas version



GIRBAU S.A. reserves the right to change specifications without notice

# E&B

## EASY & BEST SOLUTIONS

### EASY AND SUSTAINABLE SOLUTIONS

We propose a new way of working, aimed at achieving the best solution in the easiest way possible.

Just let us know your production requirements. We will take care of the rest.

**Easy and best.**



See video

# GIRBAU

GIRBAU.COM

